

# Continuous beam scanning performance of dipole array antenna coupled to meander two-wire parallel transmission line

Keisuke Konno<sup>1a)</sup>, Takashi Sekiguchi<sup>2</sup>, Hiroyasu Sato<sup>1</sup>,  
and Qiang Chen<sup>1</sup>

<sup>1</sup> Department of Communications Engineering, Graduate School of Engineering,  
Tohoku University,

6–6–05 Aramaki Aza Aoba, Aoba-ku, Sendai, Miyagi 980–8579, Japan

<sup>2</sup> Tohoku Electric Power Co., Inc.,

1–7–1 Honcho, Aoba-ku, Sendai, Miyagi 980–8550, Japan

a) [konno@ecei.tohoku.ac.jp](mailto:konno@ecei.tohoku.ac.jp)

**Abstract:** A mechanical beam scanning dipole array antenna coupled to a meander two-wire parallel transmission line is proposed. A meander transmission line is introduced to the proposed antenna in order to suppress its grating lobe without using lumped element inductors. Numerical simulation demonstrates that the proposed antenna is capable of continuous beam scanning ranging from  $2^\circ$  ( $@\phi = 0$ ) to  $42^\circ$  ( $@\phi = 180^\circ$ ) without grating lobe due to the meander transmission line.

**Keywords:** array antenna, leaky wave antenna, beam scanning

**Classification:** Antennas and Propagation

## References

- [1] K. Sakaguchi, G. K. Tran, H. Shimodaira, S. Nanba, T. Sakurai, K. Takinami, I. Siaud, E. C. Strinati, A. Capone, I. Karls, R. Arefi, and T. Haustain, “Millimeter-wave evolution for 5G cellular networks,” *IEICE Trans. Commun.*, vol. E98-B, no. 3, pp. 388–402, March 2015. DOI:10.1587/transcom.E98.B.388
- [2] H. Kamoda, T. Iwasaki, J. Tsumochi, T. Kuki, and O. Hashimoto, “60-GHz electronically reconfigurable large reflectarray using single-bit phase shifters,” *IEEE Trans. Antennas Propag.*, vol. 59, no. 7, pp. 2524–2531, July 2011. DOI:10.1109/TAP.2011.2152338
- [3] M. Khalily, R. Tafazolli, T. A. Rahman, and M. R. Kamarudin, “Design of phased arrays of series-fed patch antennas with reduced number of the controllers for 28-GHz mm-wave applications,” *IEEE Antennas Wireless Propag. Lett.*, vol. 15, pp. 1305–1308, 2016. DOI:10.1109/LAWP.2015.2505781
- [4] N. Ojaroudiparchin, M. Shen, S. Zhang, and G. F. Pedersen, “A switchable 3-D-coverage-phased array antenna package for 5G mobile terminals,” *IEEE Antennas Wireless Propag. Lett.*, vol. 15, pp. 1747–1750, 2016. DOI:10.1109/

- [LAWP.2016.2532607](#)
- [5] E. Gandini, M. Ettorre, M. Casaletti, K. Tekkouk, L. L. Coq, and R. Sauleau, “SIW slotted waveguide array with pillbox transition for mechanical beam scanning,” *IEEE Antennas Wireless Propag. Lett.*, vol. 11, pp. 1572–1575, 2012. DOI:10.1109/LAWP.2012.2235057
- [6] N. K. Host, C.-C. Chen, J. L. Volakis, and F. A. Miranda, “Ku-band traveling wave slot array scanned via positioning a dielectric plunger,” *IEEE Trans. Antennas Propag.*, vol. 63, no. 12, pp. 5475–5483, Dec. 2015. DOI:10.1109/TAP.2015.2487512
- [7] V. F. Fusco, “Mechanical Beam Scanning Reflectarray,” *IEEE Trans. Antennas Propag.*, vol. 53, no. 11, pp. 3842–3844, Nov. 2005. DOI:10.1109/TAP.2005.858828
- [8] C. J. Sletten, F. S. Holt, P. Blacksmith, Jr., G. R. Forbes, Jr., L. F. Shodin, and H. J. Henkel, “A new satellite tracking antenna,” WESCON/57 Conference Record, vol. 1, pp. 244–261, Aug. 1957. DOI:10.1109/WESCON.1957.1148737
- [9] K. Konno, K. Takeda, and Q. Chen, “Beam scanning capability and suppression of endfire radiation of dipole array antennas coupled to two-wire transmission line,” *IEICE Commun. Express*, vol. 4, no. 12, pp. 358–362, 2015. DOI:10.1587/comex.2015XBL0127
- [10] R. F. Harrington, *Field Computation by Moment Methods*, Macmillan, New York, 1968.
- [11] J. H. Richmond and N. H. Geary, “Mutual impedance of nonplanar-skew sinusoidal dipoles,” *IEEE Trans. Antennas Propag.*, vol. 23, no. 3, pp. 412–414, May 1975. DOI:10.1109/TAP.1975.1141083

## 1 Introduction

The next generation wireless communication system is expected to be operated in a high frequency band such as a millimeter wave frequency band [1]. In the millimeter wave frequency band, relatively wide bandwidth is available and an extremely high-speed wireless communication system can be developed. One of the most challenging problems for the millimeter wave wireless communication system is how to compensate a high propagation loss.

Electronic beam scanning antennas using various microwave components are promising techniques in order to compensate the high propagation loss in the millimeter wave frequency band [2, 3, 4]. The electronic beam scanning antennas are capable of scanning their main beam using active/passive microwave components such as solid state devices, phase shifters, or couplers. High signal-to-noise ratio is expected because the main beams of a transmitting and receiving antenna are directed to each other during the wireless communication. Quick response is another advantage of the electronic beam scanning antennas while their disadvantages are large insertion loss and nonlinearity.

A mechanical reconfigurable antenna is an alternative approach to develop a beam scanning antenna. Performance of the mechanical reconfigurable antenna is controlled using an actuator. The mechanical reconfigurable antenna needs no active microwave components and is free from large insertion loss and nonlinearity of them. Therefore, the mechanical reconfigurable antenna is a promising approach

in order to compensate high propagation loss in the millimeter wave frequency band. A substrate integrate waveguide (SIW) slotted array antenna [5] and a traveling wave slot array have been proposed [6]. The SIW slot antenna is operating in 24 GHz band and its  $\pm 35^\circ$  beam scanning range was demonstrated experimentally while the traveling wave antenna is operating in 13 GHz band and its  $\pm 25^\circ$  beam scanning range was demonstrated experimentally. A  $5 \times 1$  mechanical beam scanning reflectarray using a nylon gearing arrangement has been fabricated and its beam scanning performance was measured [7].

On the other hand, a mechanical beam scanning dipole array antenna coupled to two-wire parallel transmission line has been proposed and its beam scanning performance was demonstrated [8, 9]. The proposed antenna is a kind of a leaky-wave antenna and all array elements are excited via the near-field of the two-wire parallel transmission line. Beam scanning capability of the proposed antenna comes from variable array spacing which is available using an actuator. In [9], it was demonstrated that a couple of inductors loaded with the transmission line can suppress its grating lobe. The inductors are modeled as lumped elements in [9] while the size of inductors is comparable to wavelength in millimeter-wave band.

In this letter, a mechanical beam scanning dipole array antenna coupled to a meander two-wire parallel transmission line is proposed. A meander transmission line is introduced to the proposed antenna in order to suppress its grating lobe without using lumped element inductors. Numerical simulation demonstrates that the proposed antenna has a continuous beam scanning capability without the grating lobe.

## 2 Meander transmission line

According to [9], the proposed antenna has a grating lobe and inductors should be loaded with the transmission line in order to suppress the grating lobe. However, in the millimeter wave frequency band, it is difficult to deal with an inductor as a lumped element because its dimension is comparable to the wavelength. Therefore, meander structure was applied to the transmission line as the component of inductance. Fig. 1 shows the proposed antenna with the meander two-wire parallel transmission line and Table I shows its electrical parameters and dimensions. The two meander lines are parallel and the radiation from the lines is canceled because the current of the lines is the same amplitude but out of phase.

Transmission line theory is helpful in order to design the meander line because the meander line is composed of a couple of short stubs. According to the transmission line theory, a load impedance  $Z_s$  of a lossless short stub is expressed as,

$$Z_s = jZ_0 \tan(\beta l_l) \quad (1)$$

where  $\beta$  is phase constant of the transmission line,  $Z_0$  is a characteristic impedance of the stub, and  $l_l$  is the length of the stub. Once a specific value of the inductance is known, the length of the short stub to be loaded is immediately obtained from (1). In this letter,  $l_l \approx 0.1\lambda_0$  is obtained from (1) by substituting  $Z_s = j60\pi$  and  $Z_0 = 276$  which are obtained from dimensions and electrical parameters shown in Table I.

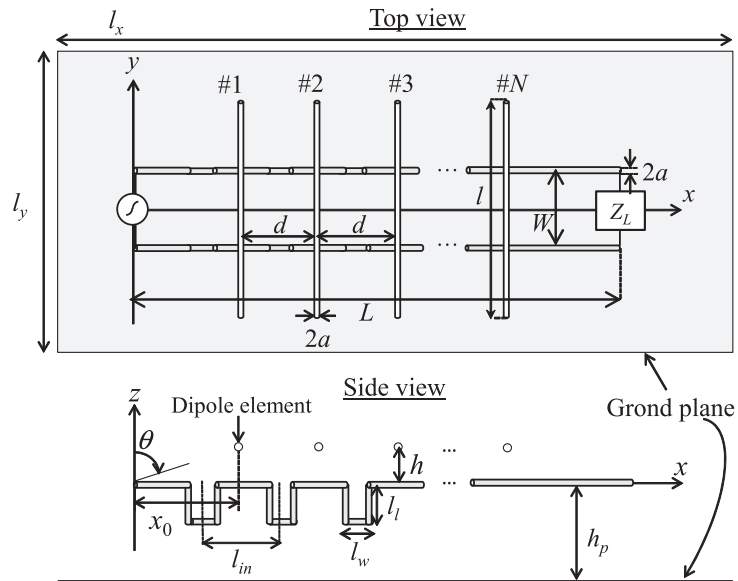

Fig. 1. Dipole array antenna coupled to meander two-wire parallel transmission line.

Table I. Electrical parameters and dimensions of antennas.

Design frequency $f$ [GHz]	30
Conductivity of antenna elements and transmission lines $\sigma$ [S/m]	$5.8 \times 10^7$ (Copper)
Conductivity of ground plane $\sigma$ [S/m]	$3.5 \times 10^7$ (Aluminium)
Load impedance $Z_L$ [ $\Omega$ ]	300
Reactance of inductors (or short stubs) $L_H$ [nH]	1
Width of short stub $l_w$ [mm]	1
Length of short stub $l_l$ [mm]	1
Spacing between two inductors (or short stubs) $l_{in}$ [mm]	7
The number of inductors (or short stubs)	9
Radius of conductors $a$ [mm]	0.1
Width of transmission line $W$ [mm]	1.22
Length of transmission line $L$ [mm]	120
Length of dipole element $l$ [mm]	5
Height of dipole elements from transmission line $h$ [mm]	0.5
Array spacing $d$ [mm]	5~8
Spacing between source and the first element $x_0$ [mm]	15
Length of ground plane in $x$ direction $l_x$ [mm]	120
Length of ground plane in $y$ direction $l_y$ [mm]	15
Height of transmission line from ground plane $h_p$ [mm]	2.5
Number of dipole elements $N$	10

### 3 Numerical simulation

Numerical simulations were performed using the method of moments (MoM) in order to demonstrate a beam scanning performance of the proposed antenna with

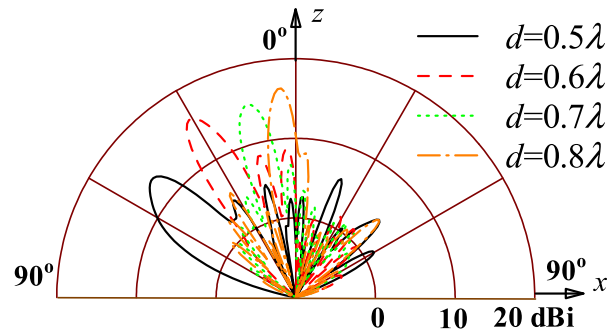

(a) Directivity of the proposed antenna with lumped element inductors ( $E_\phi$  in  $xz$  plane).

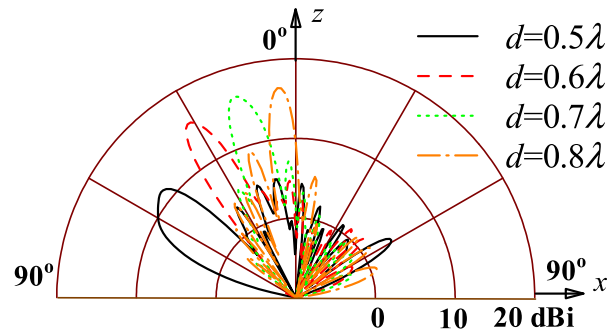

(b) Directivity of the proposed antenna with the meander line ( $E_\phi$  in  $xz$  plane).

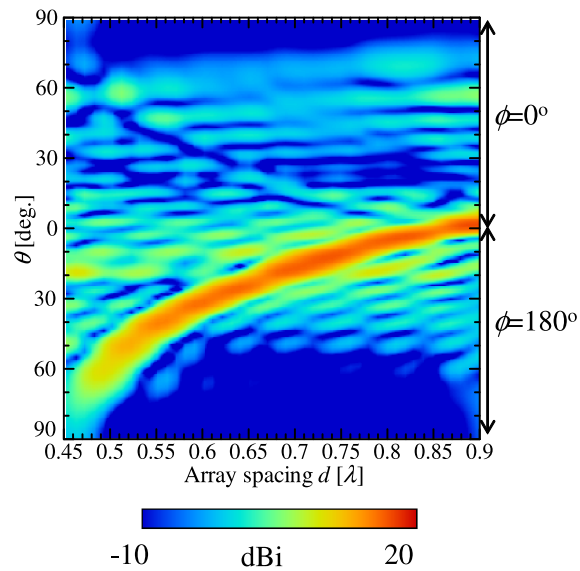

(c) Continuous beam scanning performance of the proposed antenna with the meander line ( $E_\phi$  in  $xz$  plane).

Fig. 2. Beam scanning performance.

the meander line [10, 11]. Fig. 2(a) shows a beam scanning performance of the proposed antenna with lumped element inductors while Fig. 2(b) shows a beam scanning performance of the proposed antenna with the meander line. It is found that the beam scanning performance of these antennas is in good agreement.

Therefore, it can be said that the meander line is equivalent to the transmission line with lumped element inductors.

Fig. 2(c) shows a beam scanning range of the proposed antenna at 30 GHz. Here, the beam scanning range indicates an angle region where a drop of the directivity from the maximum one is not over 3 dB. It is found that continuous beam scanning performance is available as an array spacing  $d$  varies. The maximum directivity is 17.2 dBi at  $d = 0.89\lambda_0$  and the beam scanning range is from  $2^\circ$  (@ $\phi = 0$ ) to  $42^\circ$  (@ $\phi = 180^\circ$ ).

#### 4 Conclusion

---

In this letter, a performance of the mechanical beam scanning dipole array antenna coupled to a meander two-wire parallel transmission line has been demonstrated. It has been shown that the meander line is equivalent to the transmission line with lumped element inductors and is able to suppress a grating lobe. Numerical simulation has demonstrated that beam scanning range of the proposed antenna is ranging from  $2^\circ$  (@ $\phi = 0$ ) to  $42^\circ$  (@ $\phi = 180^\circ$ ). Impedance matching and fabrication technique are not discussed here and are remaining as problems to be challenged in future.

#### Acknowledgments

---

We would like to thank staffs in Cyberscience Center, Tohoku University for their helpful advices. This work was financially supported by JSPS KAKENHI Grant Number 26820137 and JSPS Postdoctoral Fellowships for Research Abroad.